

HAND BRAKE INSTALLATION

#1 Cut off bracket and handle as shown.

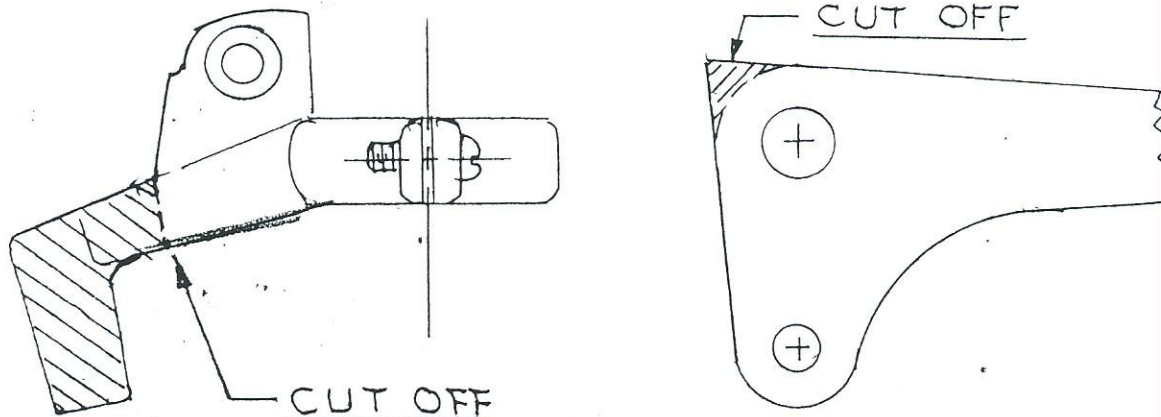

#2 Cut equalizer from 1/8" aluminum. (RS 50102)

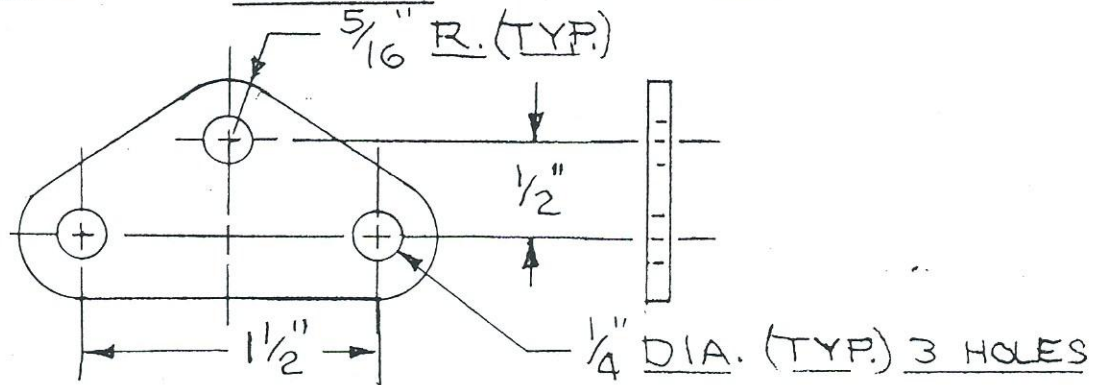

#3 Cut bracket from RS-20102 ANGLE

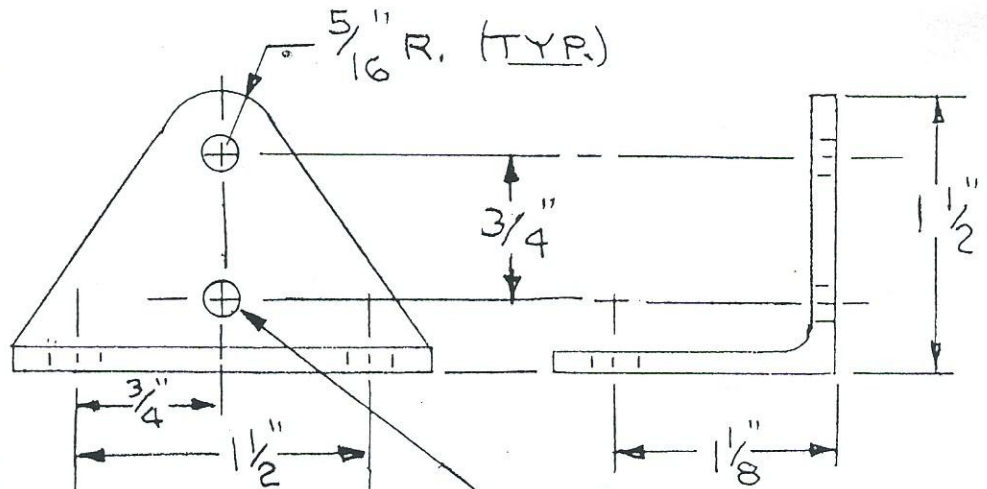

#4 Cut bushing from RS-401

#5 Drill control stick to fit bracket and bolt on.

#6 Cut and fit all cables.

#7 Drill 7/16" dia. hole in plywood lower skin, just in front of stick torque tube and run both cables out to brake arms. Avoid sharp bends and tie off housing to 1/2" dia. gear brace tubes.

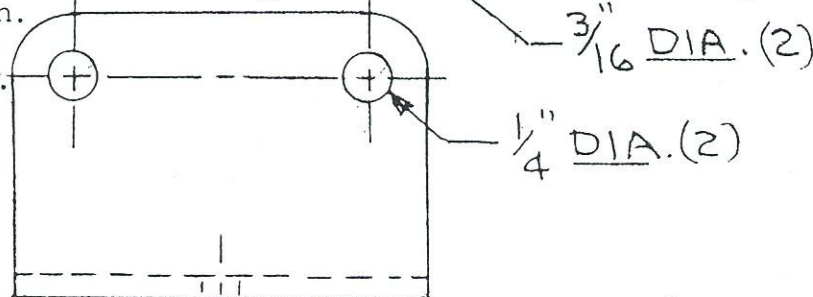

CUT BUSHING FROM RS-401.

